



NPDES Permit Number WA-0023256

FACT SHEET

Public Comment Period Start Date: March 28, 2008

Public Comment Expiration Date: April 28, 2008

**The United States Environmental Protection Agency (EPA)
Plans To Reissue A National Pollutant Discharge Elimination System (NPDES) Permit
And
Notice of State Certification**

**Suquamish Wastewater Treatment Plant
Kitsap County Public Works
18000 Suquamish Way NE
Suquamish, WA 98392**

Technical Contact:

Kai Shum

email: Shum.Kai@epa.gov

Phone: 206-553-0060

EPA Proposes To Reissue NPDES Permit

EPA proposes to reissue the NPDES permit to the facility referenced above. The draft permit places conditions on the discharge of pollutants from the wastewater treatment plant to waters of the United States. In order to ensure protection of water quality and human health, the permit places limits on the types and amounts of pollutants that can be discharged from the facility.

This Fact Sheet includes:

- information on public comment, public hearing, and appeal procedures
- a listing of proposed effluent limitations, and other conditions for the facility
- a map and description of the discharge location
- technical material supporting the conditions in the permit

401 Certification for Facilities that Discharge to State Waters

EPA is requesting that the Washington State Department of Ecology (Ecology) certify the NPDES permit for this facility, under Section 401 of the Clean Water Act. Washington State Department of Ecology is considering the issuance of a Clean Water Act (CWA) Section 401 Certification that the subject discharge will comply with the applicable Washington State Water Quality Standards. The NPDES permit will not be issued until the certification requirements of Section 401 have been met.

Public Comment

Persons wishing to comment on, or request a Public Hearing for, the draft permit for this facility, may do so in writing by the expiration date of the Public Comment period. A request for a Public Hearing must state the nature of the issues to be raised as well as the requester's name, address and telephone number. All comments and requests for Public Hearings must be in writing and should be submitted to EPA as described in the Public Comments Section of the attached Public Notice.

After the Public Notice expires, and all comments have been considered, EPA's Regional Director for the Office of Water and Watersheds will make a final decision regarding permit reissuance. If no substantive comments are received, the tentative conditions in the draft permit will become final, and the permit will become effective upon issuance. If comments are received, EPA will address the comments and issue the permit. The permit will become effective 30 days after the issuance date, unless an appeal is submitted to the Environmental Appeals Board within 30 days.

Documents are Available for Review.

The draft NPDES permit and related documents can be reviewed or obtained by visiting or contacting EPA's Regional Office in Seattle between 8:30 a.m. and 4:00 p.m., Monday through Friday (see address below). The draft permit, fact sheet, and other information can also be found by visiting the Region 10 website at "www.epa.gov/r10earth/water.htm."

United States Environmental Protection Agency
Region 10
1200 Sixth Avenue, Suite 900, OWW-130
Seattle, Washington 98101
(206) 553-2108 or
1-800-424-4372 (within Alaska, Idaho, Oregon and Washington)

The fact sheet and draft permit are also available at:

EPA Washington Operations Office
300 Desmond Drive SE
Lacey, Washington 98503
(360)-407-7564 or (800) 917-0043

Natural Resources
Suquamish Tribal Center
Port Madison Indian Reservation
15838 Sandy Hook Road
Suquamish, WA 98370

Water Quality Permit Coordinator
Washington Department of Ecology
Northwest Regional Office
3190 - 160th Avenue SE
Bellevue, WA 98008-5452
Attn: Mike Dawda
(425) 649-7207

TABLE OF CONTENTS

LIST OF TABLES 2

ACRONYMS 3

I. APPLICANT 4

II. FACILITY INFORMATION 4

III. RECEIVING WATER 8

A. Water Quality Standards 8

B. Water Quality Limited 9

IV. EFFLUENT LIMITATIONS 10

A. Basis for Permit Effluent Limits 10

B. Proposed Effluent Limitations 10

V. MONITORING REQUIREMENTS 12

A. Basis for Effluent and Surface Water Monitoring 12

B. Effluent Monitoring 12

C. Proposed Receiving Water Monitoring 13

VI. SLUDGE (BIOSOLIDS) REQUIREMENTS 13

VII. OTHER PERMIT CONDITIONS 14

A. Quality Assurance Plan 14

B. Operation and Maintenance Plan 14

C. Additional Permit Provisions 14

VIII. OTHER LEGAL REQUIREMENTS 15

A. Endangered Species Act 15

B. Essential Fish Habitat 15

C. State Certification 16

D. Permit Expiration 16

Appendix A - Facility Information 17

Appendix B - Basis for Effluent Limitations 20

Appendix C – Reasonable Potential Calculations 31

LIST OF TABLES

LIST OF TABLES 2

Table 1: Effluent Limitations from the Previous Permit 6

Table 2: Monitoring Requirements from the Previous Permit 6

Table 3: Effluent Monitoring Data from Permit Application 7

Table 4: Monthly, Weekly and Daily Maximum Effluent Limitations 11

Table 5: Effluent Monitoring Requirements 12

Table A-1: Summary of Suquamish Wastewater Treatment Plant 17

Table A-2: Location Map 18

Table A-3: Diffuser Diagram 19

Table A-4: Process Flow Diagram 20

Table B-1: Secondary Treatment Effluent Limits (40 CFR 133.102) 22

Table B-2: Analysis of Effluent Discharged 22

Table B-3: pH Calculation 27

Table B-4: Calculation of Seawater Fraction of Un-ionized Ammonia 28

Table C-1: Visual Plumes Output For Acute Scenario 33

Table C-2: Visual Plumes Output for Chronic Scenario 34

Table C-3: Reasonable Potential Calculation for Ammonia 35

ACRONYMS

AML	Average Monthly Limit
BOD ₅	Biochemical oxygen demand, five-day
°C	Degrees Celsius
cfs	Cubic feet per second
CFR	Code of Federal Regulations
CV	Coefficient of Variation
CWA	Clean Water Act
DMR	Discharge Monitoring Report
DO	Dissolved oxygen
EFH	Essential Fish Habitat
EPA	U.S. Environmental Protection Agency
ESA	Endangered Species Act
I/I	Inflow and Infiltration
lbs/day	Pounds per day
LTA	Long Term Average
mg/L	Milligrams per liter
ml	milliliters
ML	Minimum Level
µg/L	Micrograms per liter
mgd	Million gallons per day
MDL	Maximum Daily Limit
N	Nitrogen
NMFS	National Marine Fisheries Service
NPDES	National Pollutant Discharge Elimination System
OWW	Office of Water and Watersheds
O&M	Operations and maintenance
POTW	Publicly owned treatment works
QAP	Quality assurance plan
RP	Reasonable Potential
RPM	Reasonable Potential Multiplier
SBR	Sequencing Batch Reactor
s.u.	Standard Units
TMDL	Total Maximum Daily Load
TSD	Technical Support document (EPA, 1991)
TSS	Total suspended solids
USFWS	U.S. Fish and Wildlife Service
USGS	United States Geological Services
UV	Ultraviolet radiation
WLA	Wasteload allocation
WQBEL	Water quality-based effluent limit
WWTP	Wastewater treatment plant

I. APPLICANT

This fact sheet provides information on the draft NPDES permit for the following entity:

Kitsap County Public Works
Suquamish Wastewater Treatment Plant
NPDES Permit Number: WA-002325-6

Mailing Address:
12351 Brownsville Highway NE
Poulsbo, Washington 98370

Physical Address:
18000 Suquamish Way NE
Suquamish, WA 98392

Facility Contacts:
Craig Hanson (Laboratory Supervisor) 360-337-5658
Barry Loveless (Senior Program Manager, Wastewater Division) 360-337-5777

II. FACILITY INFORMATION

The Suquamish Wastewater Treatment Plant (WWTP), located on the Port Madison Indian Reservation, collects sewage in a separate sanitary sewer collection system and treats the sewage through secondary treatment and ultraviolet disinfection. The facility is owned and operated by the Kitsap County Public Works. According to its permit application package, dated December 21, 2006, the system serves a population of 1,871, has a sustainable design flow rate of 0.4 million gallons per day (mgd).

The Suquamish WWTP originally consisted of an activated sludge process followed by chlorination. This older system had a design flow rate of 0.20 mgd and was built in the 1970s. In 1998, Kitsap County replaced the old plant with the current Sequencing Batch Reactor (SBR) Plant at the same location. The equalization tank and the solids holding tank were constructed from the skeleton of the old plant. The generator and office space are housed in the old operations building; all other structures were built in 1998. The new plant consists of two SBRs with an equalization tank and a UV-disinfection channel. Flow into the plant is screened through a rotary bar screen and then sent to a grit chamber for grit removal. Flow then enters one of two SBR basins, where it is aerated, mixed, and allowed to settle. The supernatant from the settled reactor is decanted to the equalization basin. A flow valve downstream of the equalization basin regulates flow to the UV channel. The disinfected effluent is discharged through an outfall into the Port Madison Bay in Puget Sound (refer to Location Map in Table A-2).

The original outfall, constructed in the mid-1970s, is still used with the new plant. The plant discharges into Port Madison Bay in Puget Sound at the approximate location: latitude: 47° 43' 32" N; and longitude: 122° 32' 49" W. The outfall is equipped with a diffuser, has approximately 2285 feet of marine piping, and is approximately 43.4 feet below the water surface (MLLW). According to Craig Hanson (Kitsap County Public Works), the diffuser consists of a 12" diameter ductile iron pipe with four diffuser ports. Construction drawings show two of these ports are 6", one is 4", and a partially circular port at the end of the pipe. The 6" ports are opposite each other and discharge horizontally. The 4" port is at the top of the pipe and approximately 9 feet past the other ports. The diffuser ends with another port at the end of the pipe. A diagram of the diffuser is shown in Table A-3.

Based on data from January to November 2007, sludge accumulated at this plant was thickened to approximately 2.8% and then transported by a tanker truck to the Central Kitsap Wastewater Treatment Plant for further treatment. Approximately 6,500 gallons of sludge were transferred to the Central Kitsap WWTP each month, for a total of 691,000 gallons (57.0 dry tons) in 2006. At the Central Kitsap WWTP, the sludge is processed through anaerobic digesters and then centrifuged to approximately 22% total solids. The biosolids were trucked to Fire Mountain Farms in Cinebar, Washington for land application. However in the future, according to Kitsap County, depending on cost and other factors, the biosolids generated could be hauled to other facilities for either land application or for composting.

There are no industrial discharges to this WWTP. Several commercial facilities discharge sewage to this WWTP; otherwise, all other users are residential.

The previous NPDES Permit for this facility became effective on October 25, 1990, and expired on March 9, 1995. A recently updated permit application was received from the facility on December 26, 2006. Because the permit application was received in a timely manner, permit conditions from the previous permit have been administratively extended until the NPDES permit is re-issued. EPA Region 10 has received all Discharge Monthly Reports (DMRs) from the facility from January 2001 to September 2007.

In the previous permit, the following effluent discharge limitations were required:

Table 1: Effluent Limitations from the Previous Permit				
Effluent Characteristics	Units	Monthly Average	Weekly Average	Daily Maximum
Carbonaceous Biochemical Oxygen Demand, CBOD ₅	Mg/L (lbs/day)	25 (42)	40 (67)	---
Total Suspended Solids, TSS	mg/L (lbs/day)	30 (50)	45 (75)	---
Fecal Coliform Bacteria	number/100 mL	200	400	---
pH	Shall not be less than 6.0, nor greater than 9.0			
Percent Removal for BOD ₅	For any month, the monthly average effluent load shall not exceed 25 mg/L or 15% of the monthly average influent load, whichever is more stringent.			
Percent Removal for TSS	For any month, the monthly average effluent load shall not exceed 30 mg/L or 15% of the monthly average influent load, whichever is more stringent.			
Total Available (Residual) Chlorine	Chlorine shall be maintained which is sufficient to attain the Fecal Coliform limits specified above. Chlorine concentrations in excess of that necessary to reliably achieve the limits shall be avoided.			

The following table summarizes the monitoring requirements from the previous permit, effective date of October 25, 1990.

Table 2: Monitoring Requirements from the Previous Permit				
Parameter	Units	Sample Location	Sampling Frequency	Type of Sampling
Total Flow	MGD	Chlorinated effluent	Continuous	Direct Measure
BOD ₅	Mg/L and lbs/day	Raw Sewage	2/month	24 hour composite
CBOD ₅	Mg/L and lbs/day	Raw Sewage and Unchlorinated Effluent	1/week	24 hour composite
TSS	Mg/L and lbs/day	Raw Sewage and Unchlorinated Effluent	1/week	24 hour composite
pH	s.u.	Chlorinated	5/week	Grab

Table 2: Monitoring Requirements from the Previous Permit				
Parameter	Units	Sample Location	Sampling Frequency	Type of Sampling
		Effluent		
Fecal Coliform Bacteria	Number/100 mL	Chlorinated Effluent	3/week	Grab
Total Available Residual Chlorine	mg/L	Chlorinated Effluent	5/week	Grab

The facility reported the following maximum daily discharge in its Effluent Testing Data at Item B.6 of its permit application:

Table 3: Effluent Monitoring Data from Permit Application	
Pollutant	Max. Daily Discharge Concentration in mg/l
Ammonia	47.9
Dissolved Oxygen	5.0
Total Kjeldahl Nitrogen (TKN)	37.2
Nitrate Plus Nitrite	4.5
Oil and Grease	3.6
Phosphorus (Total)	7.39
Total Dissolved Solids (TDS)	578

In its NPDES Permit Application dated December 21, 2006 and in subsequent e-mails (which are referenced in Section IV), the facility reported the following information:

- The facility has a design flow rate of 0.4 mgd.
- The facility is requesting to renew its NPDES permit for continuous discharge
- The annual average daily flow rate in 2006 was 0.23 mgd.
- The facility's collection system consists only of separate sanitary sewers. No contribution from a combined storm sewer was indicated.
- The facility does not land-apply treated wastewater.
- The facility does not discharge or transport treated or untreated wastewater to another treatment works.
- The facility treats waste with two SBRs to achieve secondary treatment.
- The facility uses ultraviolet disinfection of effluent.
- The facility reported the following effluent testing information in Item A.12 of the permit application:

- Minimum pH: 6.5 s.u.
- Maximum pH: 7.9 s.u.
- Maximum daily value for flow rate: 0.62 mgd
- Average daily value for flow rate: 0.19 mgd
- Temperature of effluent - Maximum Daily value (Winter): 18 °C
- Temperature of effluent - Maximum Daily value (Summer): 22 °C
- Carbonaceous Biochemical Oxygen Demand (CBOD₅): maximum daily discharge, 21.0 mg/L; average daily discharge, 4.7 mg/L
- Fecal Coliform: Maximum Daily Discharge, 4167 organisms/100 ml; Average Daily Discharge of 4 organisms/100 ml with 713 samples.
- Total Suspended Solids (TSS): Maximum Daily Discharge, 72.8 mg/L; Average Daily Discharge, 5.84 mg/L
- Inflow and Infiltration (I/I) rate: 117,440 gallons per day

On November 20, 2007, EPA performed a site visit as part of issuing the proposed NPDES permit. EPA met with representatives from the Kitsap County Public Works, and observed the basic operation of the wastewater treatment plant. EPA was provided a copy of the Process Flow Diagram shown in Table A-4.

On December 19, 2007, EPA provided copies of the preliminary draft Permit and Fact Sheet to Washington State Department of Ecology, Washington State Department of Health and the Port Madison Indian Reservation for review. EPA has made minor changes and believes it has addressed all outstanding issues, and has received conditional preliminary determination from Ecology that the draft permit would comply with Chapter 173-201A of the Washington Administrative Code (Water Quality Standards for Surface Waters of the State of Washington).

III. RECEIVING WATER

The Suquamish WWTP discharges into Port Madison Bay in Puget Sound from Outfall 001. The marine outfall pipe is approximately 2285 feet in length from the shoreline, and the diffuser is located about 43.4 feet below the surface (MLLW). The Washington State Department of Ecology has designated this receiving water with Waterbody Identification Number, 1224819475188.

A. Water Quality Standards

Section 301(b)(1)(c) of the CWA requires the development of limitations in permits necessary to meet water quality standards. Federal regulations in 40 CFR 122.4(d) prohibit the issuance of an NPDES permit which does not ensure compliance with the water quality standards of all affected States.

A State's water quality standards are composed of use classifications, numeric and/or narrative water quality criteria, and an anti-degradation policy. The use classification system designates the beneficial uses (such as cold water biota, contact recreation, etc.) that each water body is expected to achieve. The numeric and/or narrative water quality criteria are the criteria deemed necessary, by the State, to support the beneficial uses as well as to maintain and protect various levels of water quality and uses.

The receiving water, Port Madison Bay in Puget Sound, is classified as Extraordinary Marine according to the State of Washington's water quality standards (found at WAC 173-201A as amended in November, 2006). Waters classified as "Extraordinary" have a general description of: "extraordinary quality salmonid and other fish migration, rearing, and spawning; clam, oyster, and mussel rearing and spawning; crustaceans and other shellfish (crabs, shrimp, crayfish, scallops, etc) rearing and spawning."

WAC 173-201A-400(7)(b)(i) defines the mixing zone for estuarine receiving waters. The mixing zone is determined by adding 200 feet to the depth of water over the discharge port as measured during Mean Lower Low Water (MLLW). The facility's permit application indicates that the level of water over the discharge port is 44 feet, and clarified by email that the water depth is "-43.4 feet MLLW". Therefore, the chronic mixing zone is 243.4 feet. WAC 173-201A-400(8)(b) indicates that the maximum size of the mixing zone where acute criteria may be exceeded is 10% of the mixing zone defined in WAC 173-201A-400(7)(b). In the case of the Suquamish facility, the acute mixing zone is therefore 24.3 feet.

B. Water Quality Limited Segment

Any waterbody for which the water quality does not, and/or is not expected to meet, applicable water quality standards is defined as a "water quality limited segment." According to Washington State Department of Ecology, the 2004 approved 303(d) list indicate that Temperature and Dissolved Oxygen for Port Madison are listed as Categories 1 and 2. Ammonia, pH and Fecal Coliform are listed as Category 1. Category 1 means the most recent data indicates the water body segment meets water quality standards for the parameter measured. Category 2 means water that show some evidence of a water quality problem, but short of impairment.

EPA contacted the Northwest Office of the Washington State Department of Ecology to determine if there were any TMDLs completed or scheduled for Port Madison in Puget Sound. The Office responded and indicated that there were no TMDLs completed or scheduled for Port Madison (E-mail from Dave Garland,

Watershed Unit Supervisor, Ecology Northwest Regional Office, August 8, 2007).

IV. EFFLUENT LIMITATIONS

A. Basis for Permit Effluent Limits

In general, the CWA requires that the limits for a particular pollutant be the more stringent of either technology-based effluent limits or water quality-based limits. Technology-based limits are set according to the level of treatment that is achievable using available technology. A water quality-based effluent limit is designed to ensure that the water quality standards of a waterbody are being met and they may be more stringent than technology-based effluent limits. The basis for the proposed effluent limits described in the draft permit is provided in Appendix B.

B. Proposed Effluent Limitations

The following summarizes the proposed effluent limitations that are in the draft permit.

1. **Removal Requirements for BOD₅ and TSS:** The monthly average effluent concentration must not exceed 15 percent of the monthly average influent concentration for of BOD₅ and TSS. Percent removal of BOD₅ and TSS must be reported on the Discharge Monitoring Reports (DMRs). For each parameter, the monthly average percent removal must be calculated from the arithmetic mean of the influent values and the arithmetic mean of the effluent values for that month. Influent and effluent samples must be taken over approximately the same time period.
2. There must be no discharge of any floating solids, visible foam in other than trace amounts, or oily wastes that produce a sheen on the surface of the receiving water.
3. Table 4 below presents the proposed range for pH, the concentrations and loading effluent limits for average monthly, and average weekly effluent limits for BOD₅, TSS, and fecal coliform, and the percent removal requirements for BOD₅, and TSS.

Table 4: Monthly, Weekly and Daily Maximum Effluent Limitations				
Parameters	Average Monthly Limit	Average Weekly Limit	Percent Removal	Maximum Daily Limit
BOD ₅ Concentration	30 mg/L	45 mg/L	85% (Min.) ³	---
BOD ₅ Mass-Based Limits ¹	100 lbs/day	150 lbs/day		---
TSS Concentration	30 mg/L	45 mg/L	85% (Min.) ³	---
TSS Mass-Based Limits ¹	100 lbs/day	150 lbs/day		---
Fecal coliform Bacteria (organisms/100 ml)	200 ²	400 ²	---	---
pH (in s.u.)	6.0 to 9.0			
Notes:				
<ol style="list-style-type: none"> 1. Loading is calculated by multiplying the concentration in mg/L by the average daily flow for the day of sampling in mgd and a conversion factor of 8.34. If the concentration is measured in µg/L, the conversion factor is 0.00834. For more information on calculating, averaging, and reporting loads and concentrations see the NPDES Self-Monitoring System User Guide (EPA 833-B-85-100, March 1985). 2. For fecal coliform bacteria, the permittee must report the geometric mean fecal coliform concentration. If any value used to calculate the geometric mean is less than 1, the permittee must round that value up to 1 for purposes of calculating the geometric mean. "Geometric mean" means either the nth root of a product of n factors, or the antilogarithm of the arithmetic mean of the logarithms of the individual sample values. 3. Percent removal is calculated using the following equation: $((\text{influent} - \text{effluent}) / \text{influent}) \times 100$ 				

The previous permit included limits for carbonaceous biochemical oxygen demand (CBOD), but no limits for BOD₅. Originally, these limits for CBOD were set because the original Suquamish WWTP did not produce consistent, high quality effluent, and it was thought that a significant amount of the BOD₅ was due to nitrogenous demand (e-mail communication with Craig Hanson, Kitsap Public Works, August 7, 2007). CBOD limits were based on the alternative domestic wastewater facility discharge standards and effluent limitations in WAC 173-221-050. However, the new Suquamish WWTP produces effluent that can meet secondary treatment standards (see Appendix B, Section A.1). Therefore, the proposed permit includes secondary treatment limits for BOD₅ and TSS.

As described in Section II above, the Suquamish WWTP eliminated its chlorination disinfection system in 1998 and replaced it with UV disinfection (letter from EPA to Kitsap County Department of Public Works, February 24, 1998). Therefore, chlorine requirements have been eliminated from the draft permit.

V. MONITORING REQUIREMENTS

A. Basis for Effluent and Surface Water Monitoring

Section 308 of the CWA and federal regulation 40 CFR 122.44(i) require monitoring in permits to determine compliance with effluent limitations. Monitoring may also be required to gather effluent data to determine if additional effluent limitations are required and/or to monitor effluent impacts on receiving water quality. The permittee is responsible for conducting the monitoring, for reporting results on DMRs or on the application for renewal, as appropriate, to the U.S. Environmental Protection Agency (EPA).

B. Effluent Monitoring

Monitoring frequencies are based on the nature and effect of the pollutant, as well as a determination of the minimum sampling necessary to adequately monitor the facility’s performance. Permittees have the option of taking more frequent samples than are required under the permit. These samples can be used for averaging if they are conducted using EPA approved test methods (generally found in 40 CFR 136) and if the Method Detection Limits (MDLs) are less than the effluent limits.

Table 5 summarizes the effluent monitoring requirements for the permittee in the draft permit. The sampling location must be after the last treatment unit and prior to discharge to the receiving water. If no discharge occurs during the reporting period, “no discharge” shall be reported on the DMR.

Table 5: Effluent Monitoring Requirements				
Parameter	Unit	Sample Location	Sample Frequency¹	Sample Type
Flow	MGD	Effluent	Continuous	Direct measure
BOD ₅	mg/L	Influent and Effluent	1/week	24-hour composite
	lbs/day	Influent and Effluent	1/week	Calculation ²
	% Removal	--	–	Calculation ³
TSS	mg/L	Influent and Effluent	1/week	24-hour composite
	lbs/day	Influent and Effluent	1/week	Calculation ²

Table 5: Effluent Monitoring Requirements				
Parameter	Unit	Sample Location	Sample Frequency¹	Sample Type
	% Removal	--	–	Calculation ³
Fecal coliform ⁴	#/100 ml	Effluent	3/week	Grab
Temperature ⁷	°C	Effluent	2/week	Grab
Total Ammonia as N ⁶	mg/L	Effluent	1/quarter	24-hour composite
pH	s.u.	Effluent	5/week	Grab
Alkalinity	mg/L as CaCO ₃	Effluent	1/year	Grab
NPDES Application Form 2A Effluent Testing Data ⁵	mg/L	Effluent	3/5 years ⁵	See footnote 5
Notes: 1. The sampling frequency may differ in the permit if the facility discharges intermittently. 2. Maximum daily loading is calculated by multiplying the concentration in mg/L by the average daily flow in mgd and a conversion factor of 8.34. 3. Percent removal is calculated using the following equation: $((\text{influent} - \text{effluent}) / \text{influent}) \times 100$ 4. Geometric Mean Criterion: Based on a minimum of five (5) samples taken every three (3) to seven (7) days over a thirty (30) day period 5. For Effluent Testing Data, in accordance with instructions in NPDES Application Form 2A, Part B.6, and where each test is conducted in a separate permit year during the permitted discharge period for the first three years of the permit cycle. 6. The maximum ML for Total Ammonia is 0.05 mg/l 7. Preferably temperature to be measured during the warmest period of the day.				

C. Outfall Evaluation

The dilution ratio calculations are based upon the proper function of the diffuser, and the integrity of the outfall pipe. The Permittee shall inspect the submerged portion of the outfall line and diffuser to document its integrity and continued function. The inspection shall evaluate the structural condition of the submarine portion of the outfall, determine whether portions of the outfall are covered by sediments, and determine whether all diffuser ports are flowing freely. If conditions allow for a photographic verification, it shall be included in the report. A brief report of this inspection shall be submitted to EPA.

VI. SLUDGE (BIOSOLIDS) REQUIREMENTS

Based on data from January to November 2007, sludge accumulated at this plant was thickened to approximately 2.8% and then transported by a tanker truck to the Central Kitsap Wastewater Treatment Plant for further treatment. Approximately 6,500 gallons of sludge were transferred to the Central Kitsap WWTP each month, for a total of 691,000

gallons (57.0 dry tons) in 2006.

EPA Region 10 separates wastewater and sludge permitting. Under the CWA, EPA has the authority to issue separate sludge-only permits for the purposes of regulating biosolids. EPA may issue a sludge-only permit to the facility at a later date, as appropriate.

Until future issuance of a sludge-only permit, sludge management and disposal activities at the facility continue to be subject to the national sewage sludge standards at 40 CFR Part 503 and any requirements of the State's biosolids program. The Part 503 regulations are self-implementing, which means that permittee must comply with them whether or not a permit has been issued.

VII. OTHER PERMIT CONDITIONS

A. Quality Assurance Plan

The federal regulation at 40 CFR 122.41(e) requires the permittee to develop procedures to ensure that the monitoring data submitted is accurate and to explain data anomalies if they occur. The permittee is required to develop and implement a Quality Assurance Plan within 180 days of the effective date of the final permit. The Quality Assurance Plan shall consist of standard operating procedures the permittee must follow for collecting, handling, storing and shipping samples, laboratory analysis, and data reporting. The plan shall be retained on site and made available to EPA upon request.

B. Operation and Maintenance Plan

The permit requires the permittee to properly operate and maintain all facilities and systems of treatment and control. Proper operation and maintenance is essential to meeting discharge limits, monitoring requirements, and all other permit requirements at all times. The permittee is required to develop and implement an operation and maintenance plan for the facility within 180 days of the effective date of the final permit. The plan shall be retained on site and made available to EPA upon request.

C. Additional Permit Provisions

Sections II, III, and IV of the draft permit contain standard regulatory language that must be included in all NPDES permits. Because they are regulations, they cannot be challenged in the context of an NPDES permit action. The standard regulatory language covers requirements such as monitoring, recording, reporting requirements, compliance responsibilities, and other general requirements.

VIII. OTHER LEGAL REQUIREMENTS

A. Endangered Species Act

The Endangered Species Act requires federal agencies to consult with National Oceanic and Atmospheric Administration Fisheries (NOAA Fisheries) and the U.S. Fish and Wildlife Service (FWS) if their actions could beneficially or adversely affect any threatened or endangered species. Based on findings, EPA has determined that issuance of this permit is not likely to adversely affect any threatened or endangered species in the vicinity of the discharge.

On June 20, 2007, EPA wrote to NOAA and FWS to inquire about Endangered Species in the area of Port Madison in Puget Sound. On June 28, 2007, EPA received a telephone call from Shandra O’Haleck at NOAA National Fisheries Service - (360) 753-9530 concerning EPA’s request. On a second phone conversation on June 29, we discussed ESA-Listed Marine Mammals in item (2) below.

These lists are entitled:

- (1) “***Endangered Species Act Status of West Coast Salmon & Steelhead***” – this list shows that Chinook Salmon (*O. tshawytscha*) and Steelhead (*O. mykiss*) both are listed as “Threatened” in Puget Sound. <http://www.nwr.noaa.gov/ESA-Salmon-Listings/upload/snapshot0607.pdf>
- (2) “***ESA-Listed Marine Mammals***” – Under the jurisdiction of NOAA Fisheries Service that may occur in Puget Sound, lists the following:
 - Southern Resident Killer Whale (Endangered), *Orcinus orca*;
 - Humpback Whale (Endangered), *Megaptera novaeangliae*; and,
 - Stella Sea Lion (Threatened), *Eumetopias jubatus*.

<http://www.nwr.noaa.gov/Marine-Mammals/ESA-MM-List.cfm>

Of note, according to Shandra O’Haleck, the Humpback Whale and the Stella Sea Lion are considered to have “No Effect” because they are rarely found inside Puget Sound.

B. Essential Fish Habitat

Essential fish habitat (EFH) includes the waters and substrate (sediments, etc.) necessary for fish to spawn, breed, feed, or grow to maturity. The Magnuson-Stevens Fishery Conservation and Management Act (January 21, 1999) requires EPA to consult with NOAA Fisheries when a proposed discharge has the potential to adversely affect (reduce quality and/or quantity of) EFH. The EFH regulations define an adverse effect as any impact which reduces quality and/or quantity of EFH and may include direct (e.g. contamination or physical disruption), indirect (e.g. loss of prey, reduction in species’ fecundity), site specific, or habitat-wide impacts, including individual, cumulative, or synergistic consequences of actions

In communications with NOAA, Shandra O’Haleck stated that the species lists can be found on NOAA’s website at <http://www.nwr.noaa.gov/>. In addition, NOAA

faxed the EFH list, entitled, “**Table 1. Species of fishes with designated EFH occurring in Puget Sound**”. According to NOAA, this list names the commercial fishes in Puget Sound.

Prior to the public comment period for the draft Permit, EPA also consulted with Mr. Mark Toy at the Washington State Department of Health (Office of Shellfish and Water Protection) concerning shellfish safety.

Due to the nature of this relatively small wastewater treatment plant with secondary treatment, which operates with UV disinfection, EPA has determined that issuance of this permit is not likely to adversely affect EFH in the vicinity of the discharge.

C. State Certification

Section 401 of the CWA requires EPA to seek Washington State certification before issuing a final permit. As part of its certification, Washington State may require more stringent permit conditions or additional monitoring requirements to ensure that the permit complies with water quality standards.

D. Permit Expiration

The permit will expire five years from the effective date of the permit.

Appendix A - Facility Information

Table A-1: Summary of Suquamish Wastewater Treatment Plant	
NPDES ID Number:	WA-002325-6
Mailing Address:	12351 Brownsville Highway NE Poulsbo, Washington 98370
Facility Background:	Wastewater treatment plant for domestic sewage with Secondary Treatment
<u>Collection System Information</u>	
Service Area:	Public and Tribal lands in and around the town of Suquamish, Washington.
Service Area Population:	1,871
Collection System Type:	100% Separated Sanitary Sewer
<u>Facility Information</u>	
Treatment Train:	Secondary wastewater treatment plant using sequencing batch reactor (SBR) technology
Design Flow:	0.4 mgd
Months when Discharge Occurs:	Continuous
Outfall 001 Location:	47 ⁰ 43' 32" N, 122 ⁰ 32' 49" W Port Madison Bay in Puget Sound, approx. 2285 ft. marine outfall pipe; 12-inch diameter pipe.
<u>Receiving Water Information</u>	
Receiving Water:	Port Madison in Puget Sound; Waterbody Identification Number, 1224819475188
Beneficial Uses:	Industrial water supply; salmonid and other fish migration, rearing, spawning, and harvesting; clam, oyster, and mussel and other shellfish rearing, spawning and harvesting; wildlife habitat; recreation (primary contact recreation, sport fishing, boating, and aesthetic enjoyment); and commerce and navigation
<u>Additional Notes</u>	
Basis for BOD ₅ /TSS Limits:	The facility can meet secondary treatment requirements for BOD ₅ and TSS.

Table A-3: Diffuser Diagram

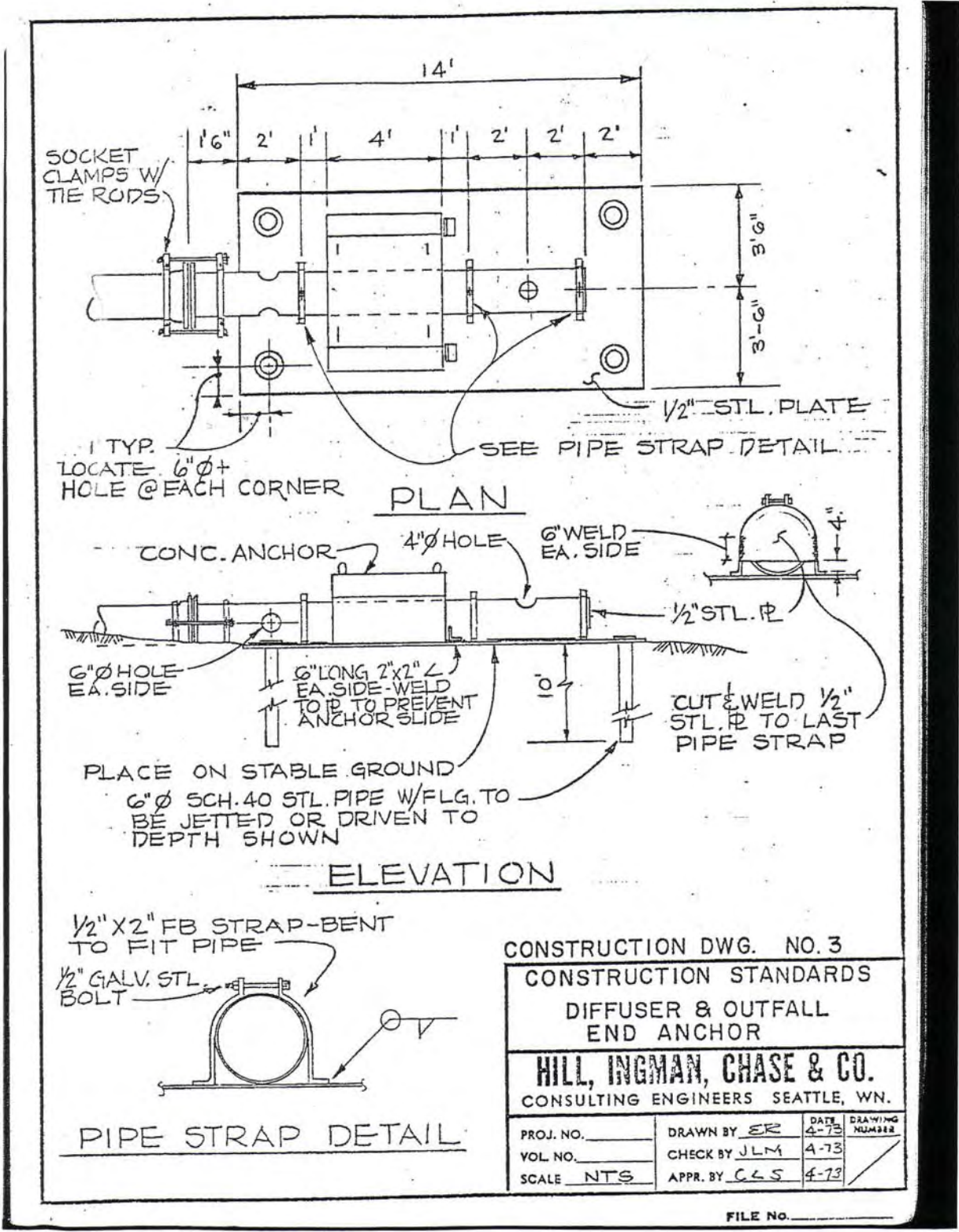
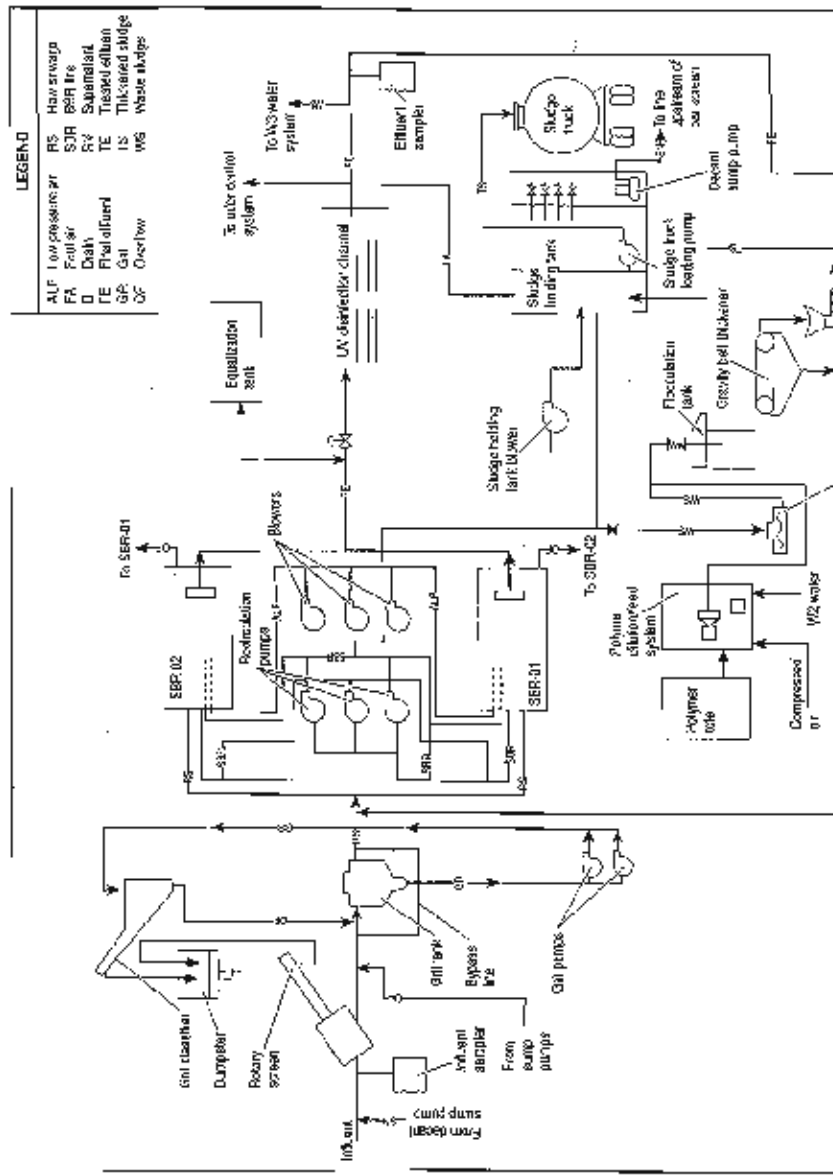

Table A-4: Process Flow Diagram



Suydamish Treatment Plant Operations Manual

Appendix B - Basis for Effluent Limitations

The Clean Water Act (CWA) requires Publicly Owned Treatment Works (POTW) to meet effluent limits based on available wastewater treatment technology. These types of effluent limits are called secondary treatment effluent limits. EPA may find, by analyzing the effect of an effluent discharge on the receiving water, that secondary treatment effluent limits are not sufficiently stringent to meet water quality standards. In such cases, EPA is required to develop more stringent water quality-based effluent limits, which are designed to ensure that the water quality standards of the receiving water are met.

Secondary treatment effluent limits may not limit every parameter that is in an effluent. For example, secondary treatment effluent limits for POTWs have only been developed for five-day biochemical oxygen demand (BOD₅), total suspended solids (TSS), and pH, yet effluent from a POTW may contain other pollutants, such as bacteria, chlorine, ammonia, or metals, depending on the type of treatment system used and the service area of the POTW (i.e., industrial facilities as well as residential areas discharge into the POTW). When technology based effluent limits do not exist for a particular pollutant expected to be in the effluent, EPA must determine if the pollutant may cause or contribute to an exceedance of the water quality standards for the water body. If a pollutant causes or contributes to an exceedance of a water quality standard, water quality-based effluent limits for the pollutant must be incorporated into the permit.

The following discussion explains in more detail the derivation of technology based effluent limits, and water quality based effluent limits. Part A discusses technology based effluent limits, and Part B discusses water quality based effluent limits.

A. Technology Based Effluent Limits

1. BOD₅, TSS and pH

Secondary Treatment:

The CWA requires POTWs to meet performance-based requirements based on available wastewater treatment technology. Section 301 of the CWA established a required performance level, referred to as “secondary treatment,” that all POTWs were required to meet by July 1, 1977. EPA developed “secondary treatment” regulations, which are specified in 40 CFR 133. These technology-based effluent limits apply to all municipal wastewater treatment plants, and identify the minimum level of effluent quality attainable by secondary treatment in terms of BOD₅, TSS, and pH.

Table B-1 below illustrates the technology based effluent limits for “Secondary Treatment” effluent limits:

Parameter	Average Monthly Limit	Average Weekly Limit	Range
BOD ₅	30 mg/L	45 mg/L	---
TSS	30 mg/L	45 mg/L	---
Removal Rates for BOD ₅ and TSS	85% (minimum)	---	---
pH	---	---	6.0 - 9.0 s.u.

Effluent monitoring data from the facility from January 2002 to June 2007 were evaluated to determine compliance with secondary treatment limits. These data are summarized in Table B-2. This analysis confirms that the facility can consistently meet secondary treatment standards. The 95th percentile values for average weekly and average monthly effluent BOD₅ and TSS are below the limits for secondary effluent, and the 5th percentile values for percent removal for BOD₅ and TSS are above the minimum of 85%.

Date	BOD Monthly Average (mg/L)	BOD Weekly Average (mg/L)	TSS Monthly Average (mg/L)	TSS Weekly Average (mg/L)	Average Monthly BOD % Removal	Average Monthly TSS % Removal
Jan-02	7.77	11.7	7.75	11.6	93.6	93.8
Feb-02	3.51	5.3	6.43	9.6	97.1	95.3
Mar-02	4.63	6.9	6.39	9.6	96.5	95.5
Apr-02	4.20	6.3	5.68	8.5	97.6	97.0
May-02	3.13	4.7	3.75	5.6	98.6	98.4
Jun-02	2.90	4.4	14.90	22.4	87.4	93.4
Jul-02	2.88	4.3	4.40	6.6	98.8	98.2
Aug-02	7.37	11.1	4.81	7.2	98.5	97.6
Sep-02	6.54	9.8	5.52	8.3	98.1	97.9
Oct-02	4.36	6.5	4.86	7.3	98.7	98.4
Nov-02	4.83	7.2	3.89	5.8	98.3	98.5
Dec-02	2.63	3.9	3.13	4.7	99.0	98.8
Jan-03	2.06	3.1	2.34	3.5	98.7	98.6
Feb-03	4.90	7.4	4.05	6.1	97.3	98.0
Mar-03	3.10	4.7	3.61	5.4	98.2	97.5
Apr-03	12.50	18.8	10.10	15.2	91.7	95.0
May-03	9.95	14.9	8.43	12.6	95.6	97.1
Jun-03	12.40	18.6	7.27	10.9	95.6	96.9
Jul-03	5.85	8.8	4.53	6.8	97.6	97.7
Aug-03	3.05	4.6	3.70	5.6	98.9	98.5
Sep-03	2.96	4.4	2.62	3.9	99.0	99.0

Table B-2: Analysis of Effluent Discharged						
Date	BOD Monthly Average (mg/L)	BOD Weekly Average (mg/L)	TSS Monthly Average (mg/L)	TSS Weekly Average (mg/L)	Average Monthly BOD % Removal	Average Monthly TSS % Removal
Oct-03	2.32	3.5	2.58	3.9	98.5	98.6
Nov-03	9.85	14.8	3.73	5.6	95.4	98.0
Dec-03	1.82	2.7	2.94	4.4	98.8	96.1
Jan-04	2.45	3.7	3.10	4.7	98.9	98.3
Feb-04	3.43	5.1	3.14	4.7	97.7	98.1
Mar-04	2.78	4.2	9.27	13.9	98.5	98.8
Apr-04	5.26	7.9	2.53	3.8	98.1	99.2
May-04	6.48	9.7	3.68	5.5	97.2	98.7
Jun-04	8.44	12.7	9.68	14.5	97.1	96.7
Jul-04	8.01	12.0	7.40	11.1	97.0	97.7
Aug-04	8.54	12.8	7.14	10.7	97.2	97.8
Sep-04	7.53	11.3	10.60	15.9	97.2	96.7
Oct-04	6.20	9.3	9.97	15.0	97.3	96.5
Nov-04	18.10	27.2	16.70	25.1	92.5	93.9
Dec-04	12.20	18.3	6.05	9.1	94.0	97.0
Jan-05	9.69	14.5	7.30	11.0	92.9	95.1
Feb-05	10.10	15.2	7.72	11.6	94.9	96.5
Mar-05	10.30	15.5	6.18	9.3	96.1	97.2
Apr-05	7.43	11.1	4.82	7.2	95.0	96.9
May-05	10.20	15.3	7.18	10.8	95.1	96.8
Jun-05	8.31	12.5	5.37	8.1	96.2	97.8
Jul-05	12.80	19.2	8.82	13.2	94.8	96.8
Aug-05	11.70	17.6	10.80	16.2	95.8	96.0
Sep-05	13.80	20.7	9.04	13.6	95.2	97.1
Oct-05	10.90	16.4	9.00	13.5	96.0	97.0
Nov-05	9.08	13.6	7.17	10.8	96.5	97.2
Dec-05	5.76	8.6	3.67	5.5	97.8	97.8
Jan-06	4.34	6.5	3.42	5.1	96.0	96.4
Feb-06	4.59	6.9	4.48	6.7	97.2	97.4
Mar-06	1.96	2.9	3.10	4.7	99.1	98.4
Apr-06	6.83	10.2	3.22	4.8	96.7	98.2
May-06	4.16	6.2	4.15	6.2	98.3	97.5
Jun-06	8.76	13.1	10.60	15.9	96.7	95.9
Jul-06	5.97	9.0	6.47	9.7	97.8	97.7
Aug-06	3.43	5.1	2.98	4.5	98.8	98.9
Sep-06	3.74	5.6	3.75	5.6	98.8	98.7
Oct-06	3.03	4.5	3.20	4.8	98.7	98.9
Nov-06	2.09	3.1	2.43	3.6	99.0	98.2
Dec-06	3.62	5.4	3.28	4.9	97.9	97.6
Jan-07	11.90	17.9	8.08	12.1	91.9	94.3
Feb-07	7.15	10.7	10.40	15.6	96.8	96.1

Table B-2: Analysis of Effluent Discharged						
Date	BOD Monthly Average (mg/L)	BOD Weekly Average (mg/L)	TSS Monthly Average (mg/L)	TSS Weekly Average (mg/L)	Average Monthly BOD % Removal	Average Monthly TSS % Removal
Mar-07	5.74	8.6	6.07	9.1	97.2	96.8
Apr-07	7.99	12.0	5.91	8.9	96.6	97.3
May-07	10.90	16.4	6.38	9.6	95.8	97.6
Jun-07	10.20	15.3	4.84	7.3	96.5	98.3
Statistical Calculations	95th percentile = 12.48	95th percentile = 18.7	95th percentile = 10.60	95th percentile = 15.9	5th percentile = 92.6	5th percentile = 94.5
Secondary Treatment Standards	30 mg/l	45 mg/l	30 mg/l	45 mg/l	85% minimum	85% minimum

2. Mass-Based Limits

The federal regulation at 40 CFR § 122.45 (f) require BOD₅ and TSS limitations to be expressed as mass based limits using the design flow of the facility. The mass based limits are expressed in lbs/day and are calculated as follows:

$$\text{Mass based limit (lbs/day)} = \text{concentration limit (mg/L)} \times \text{design flow (mgd)} \times 8.34$$

For BOD₅ and TSS:

$$\text{Average Monthly Limit} = 30 \text{ mg/L} \times 0.4 \text{ mgd} \times 8.34 = 100 \text{ lbs/day}$$

$$\text{Average Weekly Limit} = 45 \text{ mg/L} \times 0.4 \text{ mgd} \times 8.34 = 150 \text{ lbs/day}$$

B. Water Quality-Based Effluent Limits

The following discussion is divided into four sections. Section 1 discusses the statutory basis for including water quality based effluent limits in NPDES permits; Section 2 discusses the procedures used to determine if water quality based effluent limits are needed in an NPDES permit; Section 3 discusses the procedures used to develop water quality based effluent limits; and Section 4 discusses the specific water quality based limits.

The Suquamish WWTP has only technology-based limits for BOD, TSS, and bacteria. A reasonable potential analysis was conducted for ammonia. The maximum concentration of ammonia recorded from January 2002 to June 2007 was 47.5 mg/L, which was recorded in October 2005. Using a 117 point data set of ammonia concentrations dating from May 2002 to November 2006, the calculated standard deviation is 12.86, and the mean value is 15.40 mg/l. Therefore, the Coefficient of Variation, Cv was calculated to be 0.84. These data were used in Visual Plumes modeling to determine the effluent limitation for the Suquamish plant. The modeling is discussed in Appendix C, which predicted a dilution ratio 102:1 for the acute mixing zone; and, 290:1 for the chronic mixing zone.

Concerning water quality standards, pollutants in any effluent may affect the aquatic environment near the point of discharge (near field) or at a considerable distance from the point of discharge (far field). Toxic pollutants, for example, are near-field pollutants – their adverse effects diminish rapidly with mixing in the receiving water. Conversely, a pollutant such as BOD is a far-field pollutant whose adverse effect occurs away from the discharge even after dilution has occurred. Thus, the method of calculating water quality-based effluent limits varies with the point at which the pollutant has its maximum effect.

The derivation of water quality-based limits also takes into account the variability of the pollutant concentrations in both the effluent and the receiving water.

1. Statutory Basis for Water Quality-Based Limits

Section 301(b)(1)(C) of the CWA requires the development of limitations in permits necessary to meet water quality standards by July 1, 1977. Discharges to state waters must also comply with limitations imposed by the state as part of its certification of NPDES permits under section 401 of the CWA.

The NPDES regulation (40 CFR 122.44(d)(1)) implementing section 301 (b)(1)(C) of the CWA requires that permits include limits for all pollutants or parameters which are or may be discharged at a level which will cause, have the reasonable potential to cause, or contribute to an excursion above any state water quality standard, including state narrative criteria for water quality.

The regulations require that this evaluation be made using procedures which account for existing controls on point and nonpoint sources of pollution, the variability of the pollutant in the effluent, species sensitivity (for toxicity), and where appropriate, dilution in the receiving water. The limits must be stringent enough to ensure that water quality standards are met, and must be consistent with any available wasteload allocation.

2. Reasonable Potential Analysis

When evaluating the effluent to determine if water quality-based effluent limits are needed based on chemical specific numeric criteria, a projection of the receiving water concentration (downstream of where the effluent enters the receiving water) for each pollutant of concern is made. The chemical specific concentration of the effluent and receiving water and, if appropriate, the dilution available from the receiving water are factors used to project the receiving water concentration. If the projected concentration of the receiving water exceeds the numeric criterion for a specific chemical, then there is a reasonable potential that the discharge may cause or contribute to an excursion above the applicable water quality standard, and a water quality-based effluent limit is required.

Sometimes it is appropriate to allow a small area of receiving water to provide dilution of the effluent. These areas are called mixing zones. Mixing zone

allowances will increase the mass loadings of the pollutant to the water body, and decrease treatment requirements. Mixing zones can be used only when there is adequate receiving water flow volume and the receiving water is below the chemical specific numeric criterion necessary to protect the designated uses of the water body. Mixing zones must be authorized by the Washington Department of Ecology or EPA.

If a mixing zone is not granted, the water quality-based effluent limits will be recalculated such that the criteria are met before the effluent is discharged to the receiving water.

3. Procedure for Deriving Water Quality-Based Effluent Limits

The first step in developing a water quality-based permit limit is to develop a wasteload allocation (WLA) for the pollutant that has reasonable potential to exceed water quality standards. A wasteload allocation is the concentration or loading of a pollutant that the permittee may discharge without causing or contributing to an exceedance of water quality standards in the receiving water.

In cases where a mixing zone is not authorized, either because the receiving water already exceeds the criterion, the receiving water flow is too low to provide dilution, or the state/tribe does not authorize one, the criterion becomes the WLA. Establishing the criterion as the wasteload allocation ensures that the permittee will not contribute to an exceedance of the criterion. The following discussion details the specific water quality-based effluent limits in the draft permit with the expectation that the Department of Ecology would certify the final permit.

4. Specific Water Quality-Based Effluent Limits

(a) pH

The Washington water quality criterion for Extraordinary Quality Marine Waters specifies a pH range of 7.0 to 8.5 standard units, with human-caused variation within the above range of less than 0.2 units (WAC 173-201A-210(1)(f)). In the previous permit, the technology based limit allowed the range of pH from 6.0 to 9.0; in the permit application, the facility reported pH as 6.5 (minimum) to 7.9 (maximum). According to Washington Department of Ecology website which described pH data collected from Port Madison in 1995 show that (<http://www.ecy.wa.gov/apps/eap/marinewq/zero1030dataextract.asp?provisional=False&staID=95&staname=PMA001&yr=1995&mnt=1&htmlcsvoption=html&monthyearcode=for+selected+year>) pH in the receiving water was detected in the range from 7.7 to 8.5. Using a program for calculating pH, extreme inputs were used, such as the lowest pH value of effluent (6.5 units), and the highest ambient pH value recorded (8.5 units) from the link above. The analysis projected that pH changed by 0.01 units at the edge of the chronic mixing zone, and does not show that Washington

State Water Quality Standards were exceeded. Therefore, the draft permit retains the Federal Secondary Treatment standard for pH of no less than 6.0 and no greater than 9.0 standard units.

Table B-3: pH Calculation	
Based on the CO2SYS program (Lewis and Wallace, 1998)	
http://cdiac.esd.ornl.gov/oceans/co2rprt.html	
INPUT	
1. MIXING ZONE BOUNDARY CHARACTERISTICS	
Dilution factor at mixing zone boundary	290.000
Depth at plume trapping level (m)	13.230
2. BACKGROUND RECEIVING WATER CHARACTERISTICS	
Temperature (deg C):	14.00
pH:	8.50
Salinity (psu):	30.00
Total alkalinity (mmol/L)	2.30
3. EFFLUENT CHARACTERISTICS	
Temperature (deg C):	22.00
pH:	6.50
Salinity (psu)	0.00
Total alkalinity (mmol/L):	3.00
4. CLICK THE 'calculate" BUTTON TO UPDATE OUTPUT RESULTS >>>>	
	<input type="button" value="calculate"/>
OUTPUT	
CONDITIONS AT THE MIXING ZONE BOUNDARY	
Temperature (deg C):	14.03
Salinity (psu)	29.90
Density (kg/m ³)	1022.30
Alkalinity (mmol/kg-SW):	2.25
Total Inorganic Carbon (mmol/kg-SW):	1.81
pH at Mixing Zone Boundary:	<u>8.49</u>
Note: (Source: from WA Ecology Spreadsheet.) Simulation shows pH changed by 0.01 units at the edge of acute mixing zone during extreme conditions.	

(b) Ammonia

Analysis of the ammonia data from the facility were based on 117 samples, and with the maximum daily discharge of 47.9 mg/L reported in October 2005. A reasonable potential analysis was conducted to determine if ammonia had the potential to exceed these criteria.

In Washington State water quality standards, the criteria concentrations based on total ammonia for marine water can be found in EPA guidance, Ambient Water Quality Criteria for Ammonia (Saltwater) – 1989, EPA440/5-88-004. April, 1989. This document can be located from: <http://www.epa.gov/waterscience/pc/ambientwqc/ammoniasalt1989.pdf>. Using data collected by Washington Department of Ecology’s monitoring station previously located in Port Madison, EPA selected data measured in the month of August since it is typically the warmest month of the year to determine the acute and chronic water quality criteria for ammonia. Data from the month of August was used to evaluate critical conditions because typically August is one of the warmest months, and therefore calculations would most likely demonstrate worst case scenarios. Using Ecology’s data for 1992 and 1995, the only years for which August data is available, the following values of the receiving water were mathematically averaged and rounded: pH of 8, temperature of 14 degrees C, and salinity of 30 g/kg. From these parameters, criteria concentrations can be determined from the EPA guidance described above. From Text Tables 2 and 3 on pages 30 and 31, the closest values of acute and chronic criteria were determined: acute criteria of 10 mg/l, and chronic criteria of 1.6 mg/l. In addition, EPA checked these values with Ecology’s spreadsheet, using data rounded to one decimal point (pH of 8.1, temperature of 13.9 degrees C, and salinity of 29.9 g/kg), and the calculated values from the spreadsheet, Table B-4, are: acute criteria of 7.331 mg/l, and chronic criteria of 1.101 mg/l. These criteria values were used to determine reasonable potential to exceed Washington State Water Quality Standards. Using the EPA modified spreadsheet from Ecology that accounts for 99% confidence level and 99% probability basis, no reasonable potential to exceed water quality criteria was determined (See Table C-3).

Table B-4: Calculation of Seawater Fraction of Un-ionized Ammonia	
Note: Source from WA Ecology Spreadsheet	
from Hampson (1977). Un-ionized ammonia criteria for salt water are from WAC 173-201A and EPA 440/5-88-004.	
INPUT	
1. Temperature (deg C):	13.9
2. pH:	8.1

3. Salinity (g/Kg):	29.9
OUTPUT	
1. Unionized ammonia NH3 criteria (mgNH3/L)	
Acute:	0.233
Chronic:	0.035
2. Total ammonia nitrogen criteria (mgN/L)	
Acute:	7.331
Chronic:	1.101

(c) Temperature

In WAC 173-201A-210(1)(c), the Washington water quality standards limit ambient water temperature to 13.0 degrees C for marine water; when natural conditions exceed 13.0 degrees C, no temperature increases will be allowed which will raise the receiving water temperature by greater than 0.3 degrees C.

The highest ambient temperature of water in Port Madison Bay from Ecology's monitoring station on August 8, 1995 is 15 degrees C. The highest temperature of the effluent as reported in the permit application is 22 degrees C. Using the dilution ratio of 290, the predicted maximum daily temperature inside the dilution zone is: $((290 \times 15) + (1 \times 22)) / 291 = 15.02^{\circ}\text{C}$.

Since the ambient temperature increase in the receiving water is predicted to be 0.02 degrees C, which is significantly less than 0.3 degrees C, there is no potential to violate Washington State's Water Quality Standards for temperature; therefore, no effluent limit for temperature is warranted. Effluent temperature monitoring is proposed for the draft permit for comparison with past effluent, and to obtain data for potential future effluent modeling purposes.

(d) Fecal coliform bacteria

According to WAC 173-220-130(a)(i), "Fecal coliform levels shall not exceed a monthly geometric mean of 200 organisms per 100 ml with a maximum weekly geometric mean of 400 organisms per 100 ml." This technology based limits for fecal coliform bacteria is in the previous permit.

Concerning the "Shellfish harvesting bacteria criteria", WAC 173-201A-210(2)(b) states: "To protect shellfish harvesting, fecal coliform organism levels must not exceed a geometric mean value of 14 colonies/100 mL, and not have more than 10 percent of all samples (or any single sample when less than ten sample points exist) obtained for calculating the geometric mean value exceeding 43 colonies/100 mL".

Concerning Primary Contact Recreation, WAC 173-201A-210(3)(b) states: “Fecal coliform organism levels must not exceed a geometric mean value of 14 colonies/100 ml, with not more than 10 percent of all samples (or any single sample when less than ten sample points exist) obtained for calculating the geometric mean value exceeding 43 colonies/100 ml.”

Therefore, to meet both shellfish harvesting and primary contact criteria, the facility has to meet the more stringent of the two criteria at the edges of the mixing zone.

Under critical conditions (with the dilution ratio of 290:1), mathematical calculation predicts no violation of the water quality criterion for fecal coliform. In the absence of background data in the vicinity of the effluent discharge, the ambient concentration of fecal coliform was assumed to be zero. According to Ecology, ambient data at three locations in Puget Sound, at Puget Sound Main Basin – West Point (PSB 003), at East Passage Southwest of the Three Tree Point (Station EAP001), and at Port Orchard/Liberty Bay (Station POD 006), show fecal coliform concentration in the range of 1/100 ml to 2/100 ml. According to the permit application, the average daily discharge concentration out of 713 samples collected is 4 colony forming units/100 ml.

DMR data as expressed in geometric mean from January 2001 to September 2007 (81 months of data) is summarized as follows in organisms/100ml:

Monthly Average: average value = 5.74; highest value = 60

Maximum Weekly Average: average value = 31.16; highest value = 368

EPA calculated the chronic dilution ratio of 290:1 using the Visual Plumes modeling. Consistent with Ecology’s methodology, the numbers of fecal coliform bacteria were then modeled by simple mixing analysis using the technology-based (weekly maximum effluent) limit of 400 organisms per 100 ml, and the dilution factor of 290. This calculation showed that the fecal coliform concentration at the edge of the mixing zone is 1.4 organisms/100 ml, well below the State’s water quality standards of 14 organisms/100 ml. Therefore, the technology-based effluent limitation for fecal coliform bacteria (as expressed in geometric mean) was retained in the proposed permit: 200 organisms/100 ml for monthly average, and 400 organisms/100 ml for weekly average. Analyses of submitted DMR data also show that the WWTP will be able to meet the proposed effluent limits for fecal coliform.

Appendix C – Reasonable Potential Calculations

To determine if there is reasonable potential for the discharge to cause or contribute to an exceedance of water quality criteria or a given pollutant, EPA compares the maximum projected receiving water concentration to the criteria for that pollutant. If the projected receiving water concentration exceeds the criteria, there is reasonable potential to exceed Water Quality Standards (WQS), and a water quality-based effluent limit must be included in the permit. This section discusses how the maximum projected receiving water concentration is determined.

A. Visual Plumes Modeling

EPA modeled the dilution at the edges of the acute and chronic mixing zones using site-specific conditions using a Visual Plumes model. Visual Plumes (4th Edition) uses a series of dilution equations based on characteristics of the wastewater effluent and ambient receiving water to determine the physical dispersion of pollutants. For the purpose of the Suquamish WWTP NPDES permit, the UM3 (Three-Dimensional Updated Merge) model version of Visual Plumes was used. UM3 uses a Lagrangian approach which incorporates the presence of ambient current into the model. Effluent parameters for the model include design flow rate, temperature, salinity, and information on the diffuser, including the depth of the diffuser and the number of ports and their sizes, spacing, and angle-orientation. The ambient receiving water characteristics required by the model include temperature, current speed and current direction. The model enables users to model site-specific circumstances, and calculate the acute and chronic mixing zone dilution ratios.

A Brooks Farfield model approach was included in the estimation because the plume had reached the surface water before the chronic distance could be reached.

Ecology evaluated the NOAA bathymetry shape file which indicated that the depths towards Port Madison are in the order of 120 feet just past the diffuser, while the depth of Agate Passage is in the order of 20 feet. By comparison, the diffuser is located is at 43.4 feet below surface. Also, according to NOAA's website, <http://tidesandcurrents.noaa.gov/currents07/tab2pc2.html>, the current speed in Port Madison entrance is described as: "current weak and variable". In an e-mail to NOAA on October 15, 2007, EPA asked NOAA for clarification on current speeds. On October 16, 2006, William Watson of NOAA responded with the following response in an e-mail to EPA: "At this location it appears that the water column is too erratic with minimum speed passing through all points and indefinite to detect. To place a value in speed and direction will be suspect." Given the information, and the need to use a numeric value for modeling purposes, EPA determined that a 2 cm/s current speed would be considered weak, and the assumed general direction would be towards the main water-body of Puget Sound away from Port Madison Bay. EPA believes that this interpretation of a small current speed is consistent with NOAA's qualitative description and the assumed numerical small current speed of 2 cm/s may predict very conservative dilution calculations for purposes of evaluating reasonable potential to exceed WQS.

The diffuser at the WWTP has 4 ports, in 3 different sizes, and where there is are 2 grouping of 2 ports per group. EPA understands from Washington Department of Health's letter to Washington Department of Ecology (June 17, 1993) that the total port area is 94 square inches. Due to the orientation of the ports, for the purposes of modeling the plume from the diffuser, conservative

assumptions were applied to simplify the model. The actual diffuser has two groups of two ports each. For the model, two ports were assumed to be each 7.74 inches in diameter which had a total port area of 94 square inches. Because 2 larger ports were assumed in the model rather than 4 smaller ports, it is expected that the result would yield a slightly smaller dilution ratio, which is considered conservative for purposes of calculating Reasonable Potential of exceeding water quality criteria. For the model, assumptions made for at various depths of the water column were taken from Washington Department of Ecology's actual field data collected in August 8, 1995 and August 4, 1992. The values used in the model were averaged from actual values. Also assumed was the distance between ports is 10 feet. Current speed was assumed to be 2 cm/s for both near field and far field scenarios, and the effluent temperature used is 18 degrees C, which was the average daily value in summer as reported in the permit application. Washington Department of Ecology recommended that separate models be computed for the acute scenario and for the chronic scenario. Ecology recommended using the flow rate of 0.6mgd for modeling the acute scenario, which was the maximum daily flow rate reported in the permit application; and Ecology believed that it is acceptable to model the chronic scenario using 0.4mgd which is the sustainable design flow rate of the plant. Using the UM3 model and the 4/3 Power Law, the model predicted the following dilution factors in Tables C-1 and C-2.

Acute Mixing Zone dilution factor: 102

Chronic Mixing Zone dilution factor: 290

The analyses and computations of the above acute and chronic dilution factors have been reviewed by Ecology, and EPA believes the predicted dilution factors are conservative for determining if there is reasonable potential to exceed Washington Water Quality Standards.

B. Reasonable Potential Analysis

EPA used Ecology's Reasonable Potential Calculation spread sheet to determine reasonable potential to exceed the Washington State Water Quality Criteria. Modifications were made to the Ecology spread sheet to accommodate EPA's assumption of 99% probability basis. Ecology had used the recommendations in Chapter 3 of the *Technical Support Document for Water Quality-Based Toxics Control* (EPA/505/2-90-001, March 1991) (TSD) to construct its Reasonable Potential Calculation spreadsheet.

To perform the reasonable potential calculation, it is necessary to determine the Acute and Chronic Water Quality Criteria. Table C-3 shows the Reasonable Potential Calculation for ammonia since it is the only parameter that has the potential to exceed water quality standards since there are no industrial sources. The calculated values of the Washington State Water Quality Criteria for the Acute and Chronic scenario were inserted into the spreadsheet. The calculations show that there is no Reasonable Potential for ammonia to exceed Water Quality Standards; therefore no effluent calculation was performed for this parameter.

Table C-1: Visual Plumes Output For Acute Scenario

```

/ Windows UM3. 2/28/2008 11:49:22 AM
Case 1; ambient file F:\KSHUM\Suquamish\sug.2PortsAcutePeakFlow.001.db; Diffuser table record 1: -----
    Depth  Amb-cur  Amb-dir  Amb-sal  Amb-tem  Amb-pol  Decay  Far-spd  Far-dir  Disprsn
      m      m/s      deg      psu      C      kg/kg    s-1     m/s      deg     m0.67/s2
    0.0      0.02     90.0     29.75    14.74     0.0      0.0     0.02     90.0     0.0003
    2.0      0.02     90.0     29.81    14.4      0.0      0.0     0.02     90.0     0.0003
    5.0      0.02     90.0     29.83    14.2      0.0      0.0     0.02     90.0     0.0003
   10.0      0.02     90.0     29.89    13.6      0.0      0.0     0.02     90.0     0.0003
   13.0      0.02     90.0     29.92    13.4      0.0      0.0     0.02     90.0     0.0003
   13.23     0.02     90.0     29.92    13.4      0.0      0.0     0.02     90.0     0.0003
P-dia  P-elev  V-angle  H-angle  Ports  Spacing  AcuteMZ  ChrncMZ  P-depth  Ttl-flo  Eff-sal  Temp  Polutnt
(in)   (in)   (deg)   (deg)   ( )    (ft)    (ft)    (ft)    (ft)    (MGD)   (psu)   (C)   (ppm)
 7.74  12.0   90.0    0.0    2.0    10.0    24.3    243.4   42.4    0.6     0.0    18.0  100.0
Froude number:      3.751
    Depth  Amb-cur  P-dia  Polutnt  4/3Eddy  Dilutn  x-posn  y-posn
    (ft)   (cm/s)  (in)   (ppm)    (ppm)    ( )     (ft)    (ft)
  0      42.4     2.0    6.045    100.0    100.0    1.0     0.0;
 100     36.5     2.0    26.23    13.8     13.8    7.099    0.0  0.244;
 200     15.42    2.0    89.36    1.905    1.905    51.29    0.0  2.264; axial vel  0.02
 223     5.923    2.0    120.9    1.208    1.208    80.88    0.0  3.499; merging,
 232     0.67     2.0    141.1    1.011    1.011    96.65    0.0  4.267; axial vel  0.579 surface,
4/3 Power Law. Farfield dispersion based on wastefield width of 4.63 m
    conc  dilutn  width  distnce  time
    (ppm) (in)    (m)    (m)     (hrs) (kg/kg) (s-1) (cm/s)(m0.67/s2)
 0.10012  101.9   6.571   7.4  0.0847  0.0    0.0    2.0 3.00E-4 (Shows the Acute Dilution Factor is 102)
 2.14E-2  119.4   9.217  14.8  0.187   0.0    0.0    2.0 3.00E-4
 1.00E-2  136.7  12.15  22.2  0.29    0.0    0.0    2.0 3.00E-4
 6.03E-3  152.5  15.33  29.6  0.393   0.0    0.0    2.0 3.00E-4
 4.07E-3  166.9  18.76  37.0  0.496   0.0    0.0    2.0 3.00E-4
 2.95E-3  180.2  22.41  44.4  0.599   0.0    0.0    2.0 3.00E-4
 2.25E-3  192.7  26.27  51.8  0.701   0.0    0.0    2.0 3.00E-4
 1.77E-3  204.5  30.32  59.2  0.804   0.0    0.0    2.0 3.00E-4
 1.43E-3  215.6  34.57  66.6  0.907   0.0    0.0    2.0 3.00E-4
 1.18E-3  226.2  39.0   74.0  1.01    0.0    0.0    2.0 3.00E-4
 9.98E-4  236.3  43.6   81.4  1.112   0.0    0.0    2.0 3.00E-4
count: 11
;
11:49:23 AM. amb fills: 2

```

Table C-2: Visual Plumes Output for Chronic Scenario

```

/ Windows UM3. 2/28/2008 12:19:35 PM
Case 1; ambient file F:\KSHUM\Suquamish\sug.2PortsChronic.001.db; Diffuser table record 1: -----
  Depth  Amb-cur  Amb-dir  Amb-sal  Amb-tem  Amb-pol  Decay  Far-spd  Far-dir  Disprsn
    m      m/s      deg      psu      C        kg/kg    s-1     m/s      deg      m0.67/s2
  0.0     0.02     90.0     29.75    14.74    0.0      0.0     0.02     90.0     0.0003
  2.0     0.02     90.0     29.81    14.4     0.0      0.0     0.02     90.0     0.0003
  5.0     0.02     90.0     29.83    14.2     0.0      0.0     0.02     90.0     0.0003
 10.0     0.02     90.0     29.89    13.6     0.0      0.0     0.02     90.0     0.0003
 13.0     0.02     90.0     29.92    13.4     0.0      0.0     0.02     90.0     0.0003
 13.23    0.02     90.0     29.92    13.4     0.0      0.0     0.02     90.0     0.0003
  P-dia  P-elev  V-angle  H-angle  Ports  Spacing  AcuteMZ  ChrncMZ  P-depth  Ttl-flo  Eff-sal  Temp  Polutnt
  (in)   (in)   (deg)   (deg)   ( )    (ft)    (ft)    (ft)    (ft)    (MGD)   (psu)  (C)   (ppm)
  7.74   12.0   90.0   0.0     2.0    10.0    24.3    243.4   42.4    0.4     0.0    18.0  100.0
Froude number: 2.5
  Depth  Amb-cur  P-dia  Polutnt  4/3Eddy  Dilutn  x-posn  y-posn
  (ft)   (cm/s)  (in)   (ppm)    (ppm)    ( )     (ft)    (ft)
  0       42.4    2.0    100.0    100.0    1.0     0.0     0.0;
 100     37.12   2.0    22.52    13.8     7.099   0.0     0.248;
 200     19.31   2.0    75.74    1.905    1.905   51.29   0.0     2.097; axial vel  0.0126
 235     6.429   2.0    120.9    0.953    0.953  102.6   0.0     4.001; merging,
 245     0.879   2.0    145.6    0.782    0.782  125.0   0.0     4.982; axial vel  0.374 surface,
4/3 Power Law. Farfield dispersion based on wastefield width of 4.74 m
  conc  dilutn  width  distnce  time
  (ppm) (ppm)   (m)    (m)     (hrs) (kg/kg) (s-1) (cm/s)(m0.67/s2)
 6.91E-2 131.0   6.626   7.4    0.0817  0.0     0.0     2.0 3.00E-4
 1.35E-2 153.1   9.28    14.8   0.184   0.0     0.0     2.0 3.00E-4
 6.30E-3 175.2  12.22   22.2   0.287   0.0     0.0     2.0 3.00E-4
 3.76E-3 195.4  15.41   29.6   0.39    0.0     0.0     2.0 3.00E-4
 2.53E-3 214.0  18.84   37.0   0.493   0.0     0.0     2.0 3.00E-4
 1.83E-3 231.1  22.49   44.4   0.596   0.0     0.0     2.0 3.00E-4
 1.39E-3 247.1  26.35   51.8   0.698   0.0     0.0     2.0 3.00E-4
 1.09E-3 262.2  30.42   59.2   0.801   0.0     0.0     2.0 3.00E-4
 8.87E-4 276.5  34.67   66.6   0.904   0.0     0.0     2.0 3.00E-4
 7.33E-4 290.0  39.1    74.0   1.007   0.0     0.0     2.0 3.00E-4 (Shows the Chronic Dilution Factor is 290)
 6.17E-4 303.0  43.71   81.4   1.109   0.0     0.0     2.0 3.00E-4
count: 11
;
12:19:36 PM. amb fills: 2

```

Table C-3: Reasonable Potential Calculation for Ammonia

	State of Washington Water Quality Standard		Maximum concentration at edge of.....		LIMIT REQ'D?	Calculations								
	Acute	Chronic	Acute Mixing Zone	Chronic Mixing Zone		Effluent percentile value	Max effluent conc. measured (metals as total recoverable)	Coeff Variation	# of samples	Multiplier	Acute Dil'n Factor	Chronic Dil'n Factor		
Parameter	ug/L	ug/L	ug/L	Ug/L		Pn	ug/L	CV	s	n				
Ammonia in marine water (using EPA Table)	10000	1600	615.75	216.57	NO	0.99	0.975	47900.00	0.84	0.73	117	1.31	102	290
Ammonia in marine water (using Ecology Spread-Sheet)	7331	1101	615.75	216.57	NO	0.99	0.975	47900.00	0.84	0.73	117	1.31	102	290

Note: Spreadsheet is modified and based from the “Reasonable Potential Calculation” spreadsheet from the Washington Department of Ecology (<http://www.ecy.wa.gov/programs/eap/pwspspread/tsdcalc0707.xls>). The table accommodates EPA’s policy of using the statistical probability basis of 99th percentile in lieu of Ecology’s policy of 95th percentile.